

COOLING TECHNOLOGY INSTITUTE

Preparation For an Official CTI Thermal Performance, Plume Abatement, Or Drift Emission Test



This Cooling Technology Institute (CTI) publication is published as an aid to cooling tower purchasers and designers. It may be used by anyone desiring to do so, and efforts have been made by CTI to assure the accuracy and reliability of the data contained herein. However, CTI makes **NO WARRANTY OF FITNESS FOR PARTICULAR PURPOSE OR MERCHANTABILITY** nor any other warranty expressed, implied or statutory. In no event shall CTI be liable or responsible for **INCIDENTAL, CONSEQUENTIAL OR COMMERCIAL** losses or damage of any kind resulting from this publication's use; or violation of any federal, state, or municipal regulation with which this publication may conflict; or for the infringement of any patent resulting from the use of this publication.

All CTI codes and standards are copyrighted with all rights reserved to CTI. The reproduction of any part of this or any other CTI code or standard is a violation of Federal Law. One must recognize and appreciate commitment by a number of volunteer members who donate their time to develop and update CTI codes and standards. The monies spent for code development, administrative staff support and publication are essential and constitute a substantial drain on CTI. The purchase price of these documents helps to offset these costs. Reproduction and distribution by others, in addition to being unethical, undermines this system and constitutes a further financial drain on CTI. When copies are needed, CTI requests that you call or write the Cooling Technology Institute, P.O. Box 73383, Houston, Texas 77273, (281) 583-4087. Please request that your associates buy the required codes and standards rather than copy them. Your cooperation in this matter is greatly appreciated.

Nothing contained herein is to be construed as granting any right for the manufacture, sale or use in connection with any method, apparatus, or product covered by letters patent, nor as insuring anyone against liability for infringement of letters patent.

This document summarizes the best current state of knowledge regarding the specific subject. It represents a consensus of those individual members who have reviewed this document, its scope and provisions and is intended to aid all users or potential users of evaporative vapor condensers.

Approved by the CTI Executive Board.



This document has been revised and approved as part of CTI's Five Year Review Cycle. This document is again subject to review in 2019.

Approved by the
CTI Executive Board

Copyright 2014
by Cooling Technology Institute
Printed in U.S.A.

PTG-156 (14)

TABLE OF CONTENTS

Part I	Scope and Purpose	1
Part II	Introduction	1
Part III	Procedure to Obtain a Test	2
Part IV	Pre-Test and Test Activities	3
Part V	Instrumentation and Test Measurements	3
Part VI	Test Calculations and Test Reports	4
Part VII	Appendix A	4
Part VIII	Appendix B	6
Figure 1	7
Figure 2	7
Figure 3	8
Figure 4	8
Figure 5	9
Figure 6	9
Figure 7	10
Part IX	Appendix C Pre-test Checklist Guidelines	11

Preparation for an Official CTI Thermal Performance, Plume Abatement, or Drift Emission Test

Part I - Scope and Purpose

1.0 Scope - This Bulletin covers test preparation for an official water cooling tower thermal performance test, plume abatement test or drift emissions test.

- Thermal performance tests are conducted in accordance with CTI Acceptance Test Code-105 (ATC-105).

- Plume abatement tests are performed in accordance with CTI Test Acceptance Code-150 (ATC-150).

- Drift emissions tests are conducted in accordance with CTI Acceptance Test Code-140 (ATC-140).

2.0 Purpose - The purpose of this Bulletin is to describe the action required to prepare for one or more of the above specified CTI tests. Pre-test and test activities are described to allow involved parties to adequately prepare for the test.

3.0 Impartial Testing Service - It is the intention of CTI to provide independent third-party testing services. This means that any situation in which the testing agency has a material or any other interest in the outcome of the test must be avoided. The CTI- Licensed Test Agency referred to in this document shall have no connection with the manufacturer, the tower purchaser, tower owner or the Cooling Technology Institute, other than a contractual agreement with the latter. For the purposes of this document, the CTI-Licensed Test Agency is hereinafter referred to as the CTI Test Representative.

Certain categories of business interests or activities may compromise the objectivity of an agency and are considered by CTI as inappropriate for an organization licensed to provide impartial testing services. When any portion of the revenues of a testing agency or any of its corporate parents or subsidiaries is derived from these interests or activities, this will preclude that organization from consideration. The following is a non-exclusive listing of these business categories or interests:

a) The manufacture, repair, replacement or upgrade of cooling towers or cooling tower components.

b) Operation or ownership of cooling towers related to primary income generating processes.

Part II - Introduction

1.0 Introduction - The CTI provides cooling tower thermal, plume abatement and drift performance testing programs as a service to cooling tower owner/operators and manufacturers. For these programs, calibrated test equipment is provided by the CTI Test Agency performing the test. The CTI representative collects the data, evaluates the data to determine if CTI code requirements are met, calculates the test result and ultimately prepares a test report. Thermal performance

tests are conducted in accordance with ATC-105. Plume abatement tests are performed in accordance with ATC-150. Drift emission tests are conducted in accordance with ATC-140.

2.0 Test Types and Test Objectives - This document addresses the preparation for CTI Thermal Performance, Plume Abatement, or Drift Emission Tests. These tests may be further subdivided by test objective. If the test is to be used to evaluate contractual performance guarantees, then the contractually responsible parties must be invited to attend. As such, contractual acceptance tests are typically witnessed by the tower purchaser and the tower manufacturer. If the test is used to benchmark the performance of an existing tower, the test is usually witnessed by the tower owner. In either case, all interested parties should agree upon the test objectives prior to the test and if necessary a pre-test meeting shall be held to resolve the test plans. Data collection for acceptance tests and benchmark tests are usually identical. The required measurement parameters, recommended test limits and frequency of readings are given in each applicable test code. Recommended test limits including stability requirements and maximum allowable deviations from the design specifications are provided for the measurement parameters and should be adhered to whenever possible. In practice, deviations from the recommended limits may be allowed if agreed upon by the parties to the test. In some cases, it may not be possible to conduct an acceptance test if the test parties do not agree to accept the deviation(s). For benchmark tests, supplementary measurements may be required in order to achieve the test objectives of the tower owner.

2.1 Thermal Performance Tests - Simply stated, thermal performance tests are conducted to determine the ability of the tower to cool water. Operating thermal parameters including inlet wet-bulb temperature, cold water temperature, hot water temperature, water flow rate and fan motor power are measured and compared against design specifications. These design values are usually presented as performance curves in the form of cold water temperature versus inlet wet-bulb temperature as specified in ATC-105. Alternately the design may be presented as a CTI characteristic curve.

Thermal tests may be used to determine contractual acceptance on new or modified towers or to evaluate the thermal performance of an older tower. Both tests are typically conducted in the same manner and with the same caliber of instrumentation.

2.1.1 Thermal Acceptance Test - The thermal acceptance test is conducted on new and rebuilt towers, usually within the first year of operation. This

test determines whether or not the cooling tower meets contractual thermal performance guarantees by the cooling tower manufacturer or rebuilder. For a contractual acceptance test, the cooling tower manufacturer or other contractually liable parties are invited to witness, whereas the manufacturer need not be invited to witness a thermal status test.

2.1.2 Thermal Status Test - The thermal status or benchmark performance test is typically conducted on cooling towers to establish existing thermal capability. This test quantifies existing thermal performance and may be used to evaluate thermal performance degradation which may have occurred since the tower was originally placed in service. This test is often performed when tower refurbishment is being considered, when there are problems with the system indicating the tower as a possible cause, or when an additional load will be put on the tower and new operating parameters are to be determined.

2.2 Plume Abatement Test - The plume abatement test is used to evaluate the exhaust plume visibility of a wet/dry or hybrid cooling tower at a specified thermal design condition. The test results are usually evaluated against a manufacturer's guaranteed set of fogging frequency curves. The plume abatement test incorporates all of the measurements of the thermal performance test, but is usually conducted in the colder months whereas the thermal performance test is usually conducted in the summer months. In addition to the normal thermal performance test parameters, the tower exhaust air flow rate, exit wet-bulb temperature and inlet and exit dry-bulb temperatures are also measured. The test may be used either for evaluation of contractual acceptance guarantees or for benchmarking purposes.

2.3 Drift Emission Tests - Drift emissions result from the water droplets that are entrained in the exhaust air stream that exit the tower. These droplets are different from condensation, in that the drift droplets contain the same chemical constituents as the circulating water. Drift emission tests are performed to measure the amount of chemically laden circulating water that exits the tower from individual cells or entire cooling towers. The mass emission rate can be used to evaluate contractual guarantees, establish drift emission benchmarks or for environmental studies.

Part III - Procedure to Obtain a Test

1.0 Procedure - An official list of CTI Licensed Testing Agencies may be obtained from the CTI office or the the CTI Website as listed below:

Cooling Technology Institute
P.O. Box 73383
Houston, Texas 77273
Phone: (281) 583-4087
Fax: (281) 537-1721
Internet Address: www.cti.org

This list will contain contact information as well as other information about the agencies. The Test purchaser has the option to request quotes from any or all of the CTI Licensed Testing Agencies. Purchase orders are placed directly with the chosen agency, who will directly bill the test purchaser. Sufficient lead time should be allowed when ordering tests to accommodate pretest preparations, allow the CTI Test Representative (and any contractually liable representatives e.g., the tower manufacturer) to make travel arrangements, and to assure choice of the preferred test date. Although a typical test requires only 1 to 3 days of on-site efforts, allowing ample lead time is highly recommended.

Pre-test information including this bulletin may be sent to the tower owner and/or manufacturer so the advance preparations such as installing water flow measuring taps, temperature measurement taps, and scaffolding may be completed as required. The CTI Test Representative will request relevant tower design information from the tower owner and/or manufacturer.

For a Thermal Performance or Plume Abatement Test, the CTI Representative will require the following information:

- Thermal Performance Curves / Characteristic Curve
- Water flow Measurement Locations (number and size of pipes)
- Tower Type [(counterflow / crossflow), (forced/induced draft)]
- Tower Manufacturer
- Air Inlet Size (height and number of open sides)
- Anticipated Heat Load
- Nominal Fan Motor Voltage and presence of variable speed drives
- Cold Water Measurement Location (pump or cold water grid)
- Make-up and blow-down locations

For thermal performance tests of closed circuit coolers, the CTI Representative will require the additional information:

- Circulating Fluid
- Thermodynamic Properties (specific gravity, specific heat)

In addition to the above information, the CTI Test Representative will require the following information for a Plume Abatement Test:

- Plume Abatement Curve and associated Thermal Design Point
- Stack Diameter
- Stack Height
- Fan Hub Diameter and proximity to the fan stack exit plane

For a Drift Emission test, the CTI Representative will require the following information:

- Typical Circulating Water Analysis with sodium, calcium, and magnesium concentrations
- Tower Type (forced/induced draft)
- Tower Manufacturer
- Water Flow Measurement Locations (Number and size of pipes)
- Nominal Fan Motor Voltage and presence of variable speed drives
- Stack Diameter
- Stack Height
- Fan Hub Diameter and proximity to the fan stack exit plane

Part IV - Pre-Test and Test Activities

1.0 Pre-Test Activity

1.1 Site Preparation - The test purchaser is responsible for ensuring that the cooling tower is ready to test. Proper preparation will reduce pre-test time spent by the CTI Test Representative upon arrival at the test site and reduce test costs. To assist the test purchaser in test preparation, details for installation of test taps are given in Appendix A and a pre-test checklist is included as Appendix B of this Bulletin. Normal test preparation includes installation of Pitot taps for water flow measurement and possibly the erection of scaffolding. Scaffolding is usually required for safe access to elevated water flow measurement locations and for access to the fan stack exit plane as required for most plume abatement and drift emission tests. If the tower supply or return piping configuration does not allow installation of conventional instrumentation taps as shown in the Appendices, the CTI Test Representative should be contacted so that alternate methods can be recommended. Arrangements should be made for an electrician or other qualified technician/operator to be available to take fan motor power readings as required during the test.

1.2 Tower Configuration - If the heat load and/or water flow to a multi-cell tower is below the operating limits as set forth in the applicable test code, the number of cells in operation may be reduced prior to the test in order to meet code recommendations on a per-cell basis. If the cell walls do not fully partition the tower, it may be necessary to leave the fans in service. The heat load and flow rates of the operating portion of the tower should meet code requirements for heat load/water flow rate on a per cell basis as opposed to an entire tower basis. The results of the operating portion of the tower are considered representative of the entire tower if the condition of the tested cells are representative of the aggregate tower. Any deviations from the limits recommended in the applicable test code should be mutually accepted by all parties to the test.

2.0 Test Activity - Upon arrival at the test site, the CTI Test Representative will meet with test participants and discuss plans and requirements for the test. The test shall be conducted in the presence of authorized representatives of the tower purchaser and the manufacturer (acceptance test) if they desire to be present. Before this time, the cooling tower should have been inspected by the test purchaser to confirm that the tower is ready for testing following the guidelines suggested in the Pre-test Checklist contained in Appendix B. For acceptance testing these representatives shall be given adequate notice prior to the test. In no case shall any directly involved party be barred from the site.

Once the tower is ready for testing, a general meeting will be held to discuss the actual test procedures, and assignments will be made for those participating in test data collection. If necessary, the CTI Test Representative will instruct the test personnel in the proper procedures and techniques of instrument reading and data recording. The CTI Test Representative is responsible for conducting the test in accordance with the applicable test code. If operating or test conditions are outside of recommended test limits, the test will be delayed unless the authorized test parties agree to proceed with the test.

Part V - Instrumentation and Test Measurements

1.0 Thermal and Plume Abatement Test Measurements

The CTI Representative will provide sufficient calibrated instrumentation for all test data collection. A discussion of specific test measurements and measurement frequency is included in the applicable test codes. Any equipment not provided by the CTI Test Agency must meet with the approval of the CTI Test Representative and the parties to the test.

1.1 Test Instruments - Normal thermal and plume abatement test instrumentation will consist of:

1.1.1 Pitot tube, manometer, and accessories for measurement of water flow.

1.1.2 Wet bulb instruments for measurement of inlet wet-bulb temperature and/or dry-bulb temperature. Plume abatement tests require the measurement of exhaust wet-bulb and dry-bulb temperature.

1.1.3 Propeller, rotating cup, or vane anemometers are used to measure wind speed and exhaust velocity for a plume abatement or drift emission test. Alternately an S type Pitot with an inclined manometer may be used for tower exhaust velocity measurements.

1.1.4 Data acquisition systems equipped with precision temperature probes or manually read thermometers with 0.1°C (0.2°F) or smaller division may be used to measure hot water, cold water, wet-bulb and dry-bulb temperatures.

1.1.5 Clamp-on watt-meters are used to measure the fan motor power for systems with motor voltages less

than 600V. If the cooling tower is equipped with fan motors greater than 600 volts or if the system is equipped with a variable frequency drive, contact the CTI Test Representative for alternate fan motor power measurement techniques.

1.1.6 The data acquisition system may be used to collect thermal and wind speed data. The data acquisition system is optional for most smaller thermal tests but may be required for larger thermal tests and plume abatement tests.

2.0 Drift Tests - The CTI Representative will provide sufficient calibrated instrumentation for all test data collection. A discussion of specific test measurements and measurement frequency is included in ATC-140. Any equipment not provided by CTI must meet with the approval of the CTI Test Representative.

2.1 Isokinetic Sampling Train - The isokinetic sampling train major components include the heated glass bead assembly, back up filter, air flow rate measurement device, and air temperature measurement device.

2.2 Vacuum Pumps - Vacuum pumps are used to draw the air sample through the back up filter and heated glass bead pack. Special power requirements for vacuum pumps may be required (e.g. single phase 220 volt, 30 amp power).

2.3. Air Flow Measurement - Air flow rates are usually measured with a propeller anemometer or air Pitot with inclined manometer.

2.4 Water Flow Measurement - Water flow rates are usually measured with a Pitot tube equipped with an air-over-water manometer.

Part VI - Test Calculations and Test Reports

1.0 Thermal Test Calculations - Two procedures are approved for thermal performance data analysis: the performance curve method and the characteristic curve method. Of the two, the performance curve method is more widely used. In order for tower capability to be calculated the tower owner must provide one of the following to the CTI Test Representative: a set of performance curves; or the characteristic curve; or characteristic curve fill slope, design K_aV/L and design L/G . The method of data analysis will be decided before the test is started. Additional details for both the performance curves and characteristic curve are provided in ATC-105.

2.0 Plume Abatement Calculations - The calculation of plume abatement performance for contractual acceptance requires a Plume Abatement Guarantee Curve generated by the tower manufacturer. Details for the calculation of plume abatement cooling tower exhaust characteristics are provided in ATC-150.

3.0 Drift Emission Calculations - The calculation of drift emission for contractual acceptance requires the Guaranteed Drift Rate, the associated design water flow

rate and fan motor power. Drift rates for status testing may be measured in an "As-Found" condition without reference to any design specification. Details for the calculation of drift emission values are provided in ATC-140.

4.0 Test Reports and Registration - The Licensed CTI Testing Agency will submit a registration fee to CTI and assign a CTI registration number for inclusion on the final test report. A single copy of the test report will be transmitted by the CTI Testing Agency to the official test parties. In addition, a sealed copy of the test result will be archived at the CTI offices in Houston, Texas. The results of all tests are confidential; therefore, test reports, data, and results are only distributed to the official test parties unless additional recipients are mutually agreed upon. The CTI Licensed Agency will directly bill the test purchaser upon submittal of the final test report. Regardless of the type of CTI test conducted, one copy of the report is sent to each of the official test participants.

4.1 Thermal and Plume Abatement Test Reports - At the conclusion of the test, all original test data sheets will be initialed by the CTI Test Representative. Test data will be analyzed on site when possible and preliminary test results will be presented by the CTI Test Representative. The final test report will be issued within 30 days of the test completion. In addition to the test results and test data, the test report will note any deviations from the recommended test procedures in the applicable test code.

4.2 Drift Emission Test Reports - At the conclusion of the test, all original test data sheets will be initialed by the CTI Test Representative. The collected test samples will be packed and shipped to a laboratory for chemical analysis. The drift emissions report will be issued after the chemical analyses of the samples are complete. The final report will be issued within six weeks of the test completion. In addition to the calculated drift rate and test data, the test report will note any deviations from the recommended test procedures in ATC-140.

Part VII - Appendix A

1.0 General Installation of Test Taps for Water Flow- The measurement of water flow rate is required for all of the cooling tower tests addressed in this document. Water flow measurements are typically performed through the use of a Pitot tube which requires the installation of Pitot taps on the hot water lines to the tower. Pre-existing taps for the measurement of other thermal parameters (e.g. pump discharge pressure taps for cold water measurement) are usually sufficient. Additional taps beyond those required for the water flow measurement are not required for a drift test. Figures 1 and 2 show tap installations required for a typical test.

1.1 Installation of Pitot Taps for Water Flow Measurement - Pitot tube traverses of the hot water line(s) to the tower with recently calibrated Pitot tubes are the preferred water flow measurement technique. Installation

of Pitot taps is generally advised even if other flow measurement devices are already in use. Alternative measurement techniques can be addressed prior to mobilization to the test site for specific situations.

Figure 3 shows a typical installation of Pitot taps. These taps are placed 90 degrees apart in the same plane at the flow measurement location. Figure 4 shows a typical Pitot tube installation in one of the Pitot taps. When selecting the flow measurement location, consider the following:

1.1.1 The Pitot tap plane should be located in a straight section of pipe with a minimum of 10 pipe diameters downstream and 5 pipe diameters upstream from the nearest pipe fitting, valve, or other obstruction. In the absence of the total 15 diameters of straight pipe, the Pitot taps should be placed in the best 2/3-1/3 ratio of straight pipe. The absolute minimum length for the total straight run of pipe is six diameters (four upstream, two downstream), in accordance with FSP-146. The CTI Test Representative should be notified of the Pitot tap installation location and any other unusual piping configurations during the test preparation stage prior to arrival at the test site.

1.1.2 Taps may be installed on either horizontal or vertical pipe runs. Excavation of underground lines may be required. Scaffolding, or other means of access to elevated measurement stations may also be required.

1.1.3 Sufficient clearance for the insertion of the Pitot tube is required. Insertion of the Pitot tube into the Pitot tap requires unobstructed access for a distance of the pipe diameter plus 1.0-1.2 meters (3-4 feet). Care must be taken to ensure that scaffolding, walls, cross members and other obstructions are not in a direct line with the Pitot tap for a distance of the pipe diameter plus the required clearance.

1.2 If the water flow rate is to be measured by a method other than a Pitot tube or if the pipe size is less than 150 mm (6 inches) in diameter, this should be discussed with the CTI Test Representative prior to the test.

2.0 Additional Test Measurement Taps Required for Thermal or Plume Abatement Tests Only

2.1 Hot Water Temperature Measurement - Hot water temperature may be measured in a bleed stream from the hot water line to the tower, thermal well or by immersion in the hot water distribution system. The location selected should have a well-mixed uniform temperature. If different temperatures are delivered to the tower, a flow weighted average temperature will be used. Pitot tube taps are usually sufficient for hot water temperature taps.

2.2 Cold Water Temperature Measurement - Cold water temperature is usually measured in a bleed stream on the cold water supply line from the tower or with a matrix of submersible cold water temperature sensors. Any unusual cold water basin configurations should be brought to the attention of the CTI Test Representative.

2.2.1 Cold Water Temperature Tap Details - The typical cold water temperature measurement location is usually on the discharge side of the operating pumps. A thermal correction is made for the influence of the pump per the guidelines of ATC-105. Therefore, a pressure measurement at the same location will also be required. In practice, the pump pressure gauge location on the discharge side of each operating pump is usually the preferred measurement location. For these tests, the pump pressure is measured at either the beginning or the conclusion of the test. If pumps are significantly different in size, the temperature may be flow weighted using the pump curves or the nominal flow rate of the pumps. Figure 5 shows a typical temperature tap detail.

2.2.2 Cold Water Measurement Grid - Some systems combine water from more than one cooling tower before entering a pump system. Other towers operate in a helper mode and discharge cold water directly to a body of water rather than a cold water piping system. These systems typically require a data acquisition system to measure a multipoint grid (matrix) of temperature sensors in the cold water outlet stream. If cold water temperature is measured with a matrix of cold water probes, positive flow through the measurement plane is required. In unusual circumstances, the flow rate at each matrix position will be measured in order to flow weight the calculated cold water temperature. It may be necessary for the tower owner to assist with the design of a measurement support system for the temperature probes. If a grid system is to be used, the CTI Representative should be notified of the water depth and width at the measurement location in order to provide a sufficient number of thermal probes and to minimize any delay on site.

3.0 Additional Site Requirements - In addition to the test taps, the test purchaser is responsible for ensuring that power is available for test instrumentation and to provide an electrician for fan motor power measurements as required for site specific safety requirements.

3.1 Wet-Bulb Temperature Measurement - The CTI wet bulb instrument is a mechanically aspirated device which uses either thermometers or temperature probes. The temperature sensors are wrapped with a cotton wick which is wetted with distilled water. Tests performed by CTI Test Agencies from the United States typically use induction type (brushless) fan motors that require a source of 110V power (approximately 0.5 amp/instrument). If the 110 volt power is supplied on a ground fault interrupt (GFI) circuit, please notify the CTI Test Representative. If tests are to be performed by CTI Test Agencies based outside of the United States, these agencies should be contacted regarding power requirements.

Wet bulb instruments may be mounted on tripods approximately 1.5 meters (5 ft) above grade (if site conditions permit) or suspended in front of the air inlets to

measure a grid (matrix) of wet bulb temperatures. Guidelines for the number of instruments are given in the ATC-105 Test Code. If a grid of instruments is desired for the test, or the instrument location is not easily accessible, a remote reading (e.g. data acquisition) system will be required.

3.2 Fan Motor Power (if applicable) - Most cooling tower fans are driven by electric motors of 480V or less. If the motor voltage is over 600 V, the fan motor is equipped with a variable frequency drive (VFD), or the fans are not driven by electric motors, the CTI Test Representative should be contacted. The preferred method of power measurement on electrically driven fans is to measure the motor input kW and convert to output horsepower using the motor manufacturer's efficiency values. Measurement of the motor kW is usually performed at the motor control center since the wiring is usually accessible for both the required current transformer(s) and voltage tap(s) to be connected. Correction for line losses between the motor and measurement location require the average line length between the measurement point and the fan motors, and the line size. The assistance of the plant owner's electrician is usually required to gain access to the motor wiring and to assist with data collection.

3.3 Make-up/Blow-down Temperature And Flow - If an in-service make-up or blow-down stream enters or exits the tested system between the hot water temperature and the cold water temperature measurement points, then the flow rate and temperature of these streams must be recorded. If necessary contact the CTI Test Representative.

Part VIII - Appendix B

1.0 Major Item Checklist - The following provides a checklist for tower preparation. The list is not all inclusive but highlights items that may be overlooked and have historically caused delays in testing.

2.0 All Tests - Thermal, Plume Abatement and Drift Test Preparation

2.1 Test Schedule - All contractually responsible parties should be notified of the test with sufficient time in order to make travel arrangement should they intend to witness.

2.2 Pitot Traverse

2.2.1 Locate and install taps. Pre-existing valves should be checked for proper operation.

2.2.2. Provide safe and easy access to taps (scaffolding or other arrangements).

2.3 Tower Distribution System

2.3.1 Nozzles are clean of scale, debris or foreign material and all nozzles are undamaged.

2.3.2 The water flow to each cell in service can be maintained within +/- 10% of design.

2.3.3 The hot water by-pass valve can be closed leak tight.

2.4 Electrical Power

2.4.1 For tests conducted by United States based test agencies, 110V AC, 20 amp service is available near the tower. For tests conducted by non-United States Agencies, the agency should be contacted regarding electrical power requirements.

2.4.2 Notify the CTI Test Representative if power is on a GFI circuit.

2.5 Cooling Tower Fans

2.5.1 Notify the CTI Test Representative if fans are operating on variable frequency drive.

2.5.2 All fans operable on high speed and pitched to draw within 10% of design horsepower. (The fans must be in operation for all cells with water flow for the duration of the test.)

2.5.3 Plant electrician required if plant requirements dictate electrician be available for fan motor power measurement.

2.5.4 Notify the CTI Test Representative if fan motor voltage is greater than 600 V.

3.0 Thermal Performance and Plume Abatement Test Preparation

3.1 Performance Curves

3.1.1 Tower Manufacturer's Performance Curve or Characteristic Curve is available prior to the conduct of the test.

3.1.2 Fogging frequency curve is available for plume abatement test.

4.0 Drift Emissions and Plume Abatement Test Preparation

4.1 Scaffolding at quadrants around the fan stack exhaust per Figure 7.

5.0 Drift Emissions Test Preparation Only

5.1 Power Requirements - Special provisions for power may be required (e.g. single phase 220 volt 30 amp power) near the drift sampling measurement location, typically on fan deck. Power requirements should be addressed with the Licensed CTI Test Agency.

Figure 1: Typical Counterflow Cooling Tower Test Taps

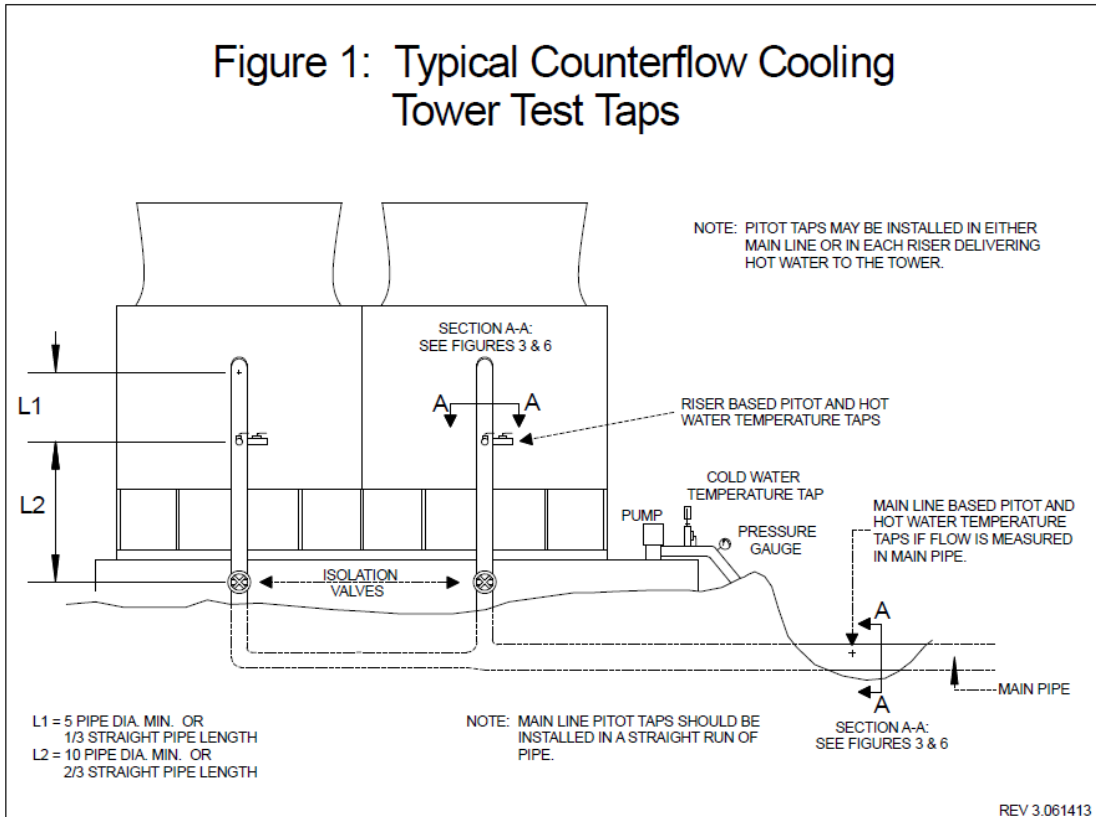

Figure 2: Typical Crossflow Cooling Tower Test Taps

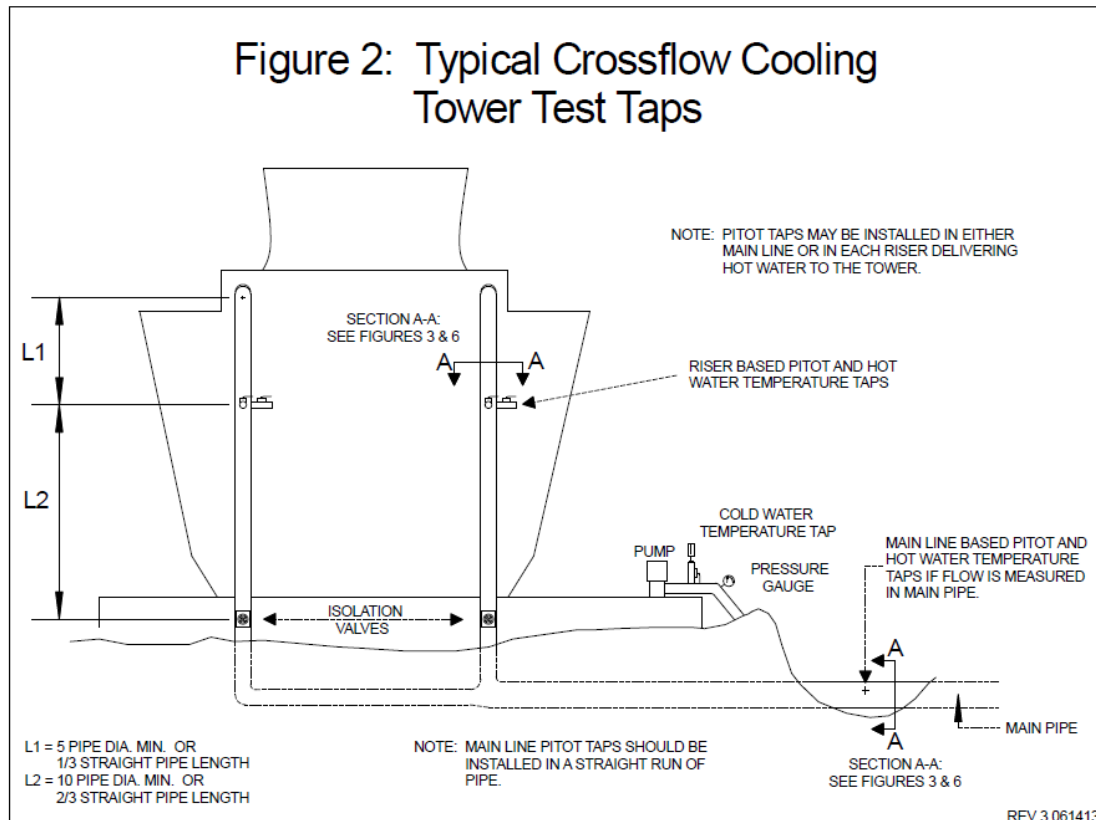

Figure 3: Pitot Tap Details (Section A-A from Fig. 1 & 2)

BALL OR GATE VALVE FOR PITOT TAPS			
PITOT TYPE	PIPE SIZE	WATER VELOCITY	VALVE, NIPPLE & PIPE WALL OPENING *
STANDARD	150mm - 1100mm (6" - 42")	< 3m/s (10 FPS) RECOMMENDED	MIN. 32mm (1.25") I.D. *
REINFORCED	900mm - 3600mm (36" - 144")	HIGHER VELOCITIES MAY BE TOLERATED	MIN. 50mm (2") I.D. *

*CAUTION: MANY COMMERCIAL VALVES AND/OR HEAVY WALL PIPE NIPPLES HAVE OPENINGS THAT ARE LESS THAN THEIR NOMINAL SIZE. THEREFORE, THE NOMINAL SIZE USED MAY HAVE TO BE INCREASED ONE OR MORE SIZES LARGER THAN THE MINIMUM SHOWN.

NOTES:

1. ALIGN VALVE CONNECTION AXIS CAREFULLY TO RADIAL PIPE AXIS & PERPENDICULAR TO PIPE LONG AXIS.
2. ALIGNMENT ORIENTATION OF VALVES WITH RESPECT TO EACH OTHER MUST BE 90°, BUT MAY BE AT ANY ORIENTATION WITH RESPECT TO EQUIPMENT AS NOTED BELOW:

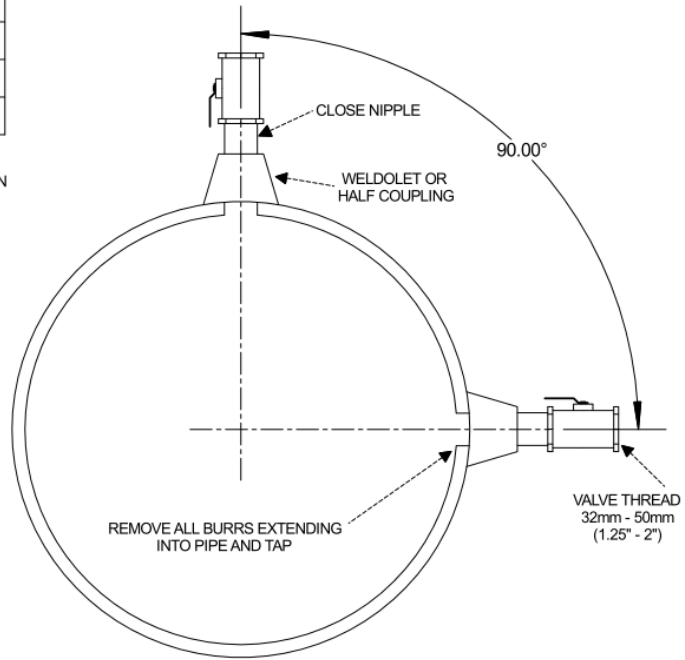
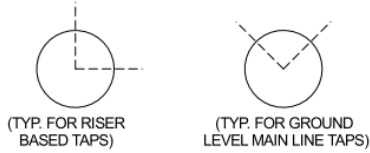

REV 2.061313

Figure 4: Pitot Tube Installation

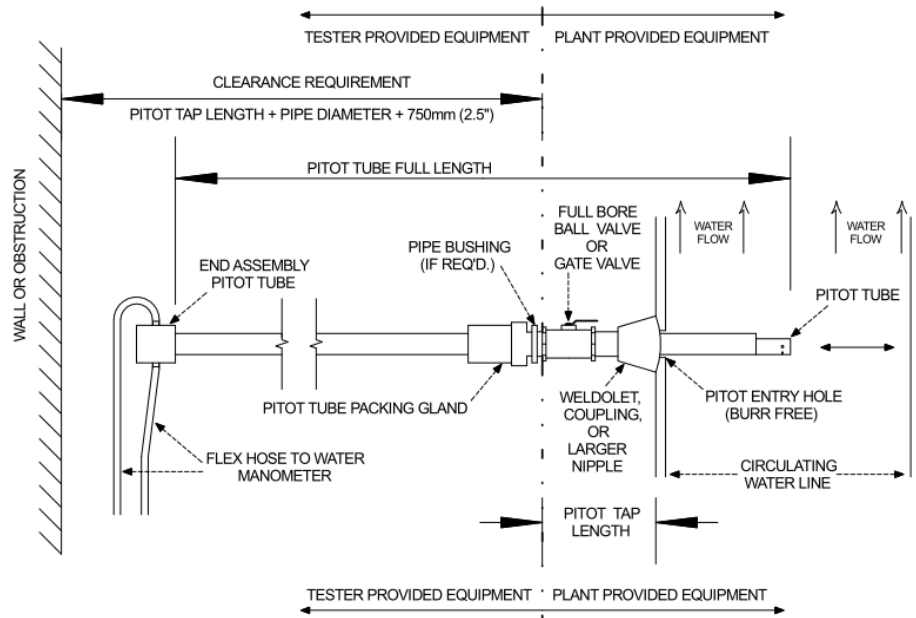

REV 1.061213

Figure 5: Temperature Tap Details

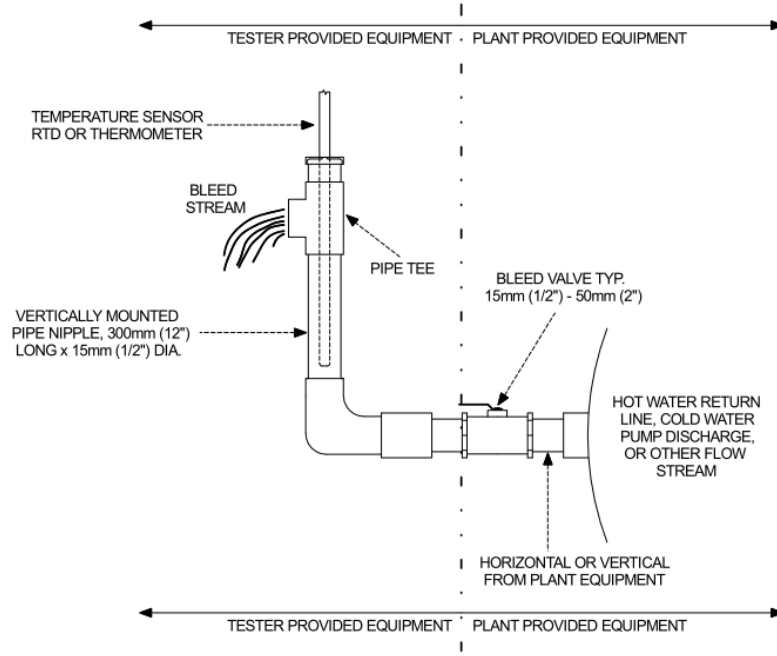

REV 1.061213

Figure 6: Typical Pitot Locations

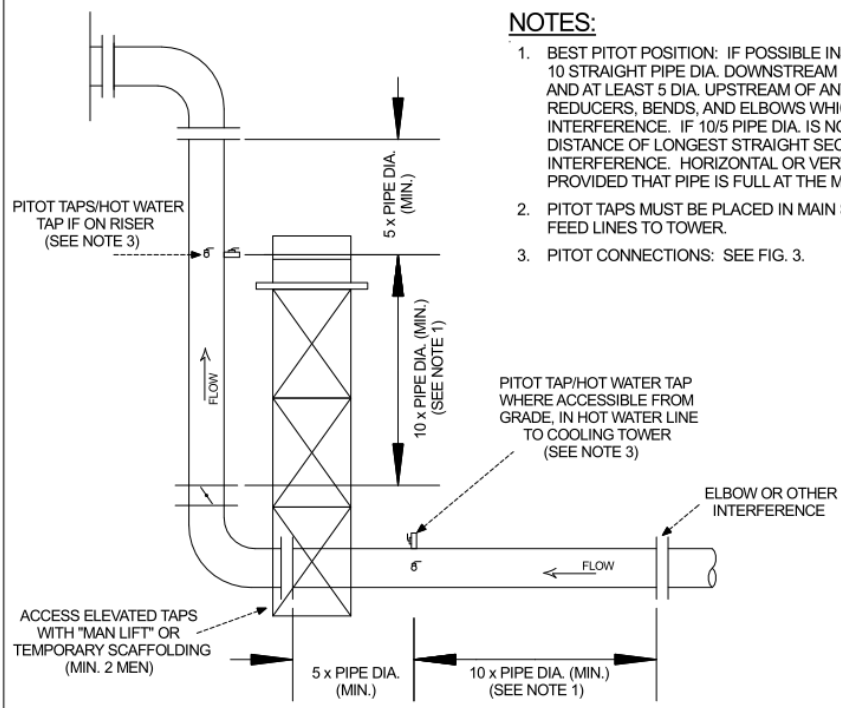

NOTES:

1. BEST PITOT POSITION: IF POSSIBLE INSTALL TAPS A MINIMUM OF 10 STRAIGHT PIPE DIA. DOWNSTREAM FROM FLOW OBSTRUCTION AND AT LEAST 5 DIA. UPSTREAM OF ANY OBSTRUCTION, INCLUDING REDUCERS, BENDS, AND ELBOWS WHICH COULD CAUSE INTERFERENCE. IF 10/5 PIPE DIA. IS NOT POSSIBLE: PLACE TAPS 2/3 DISTANCE OF LONGEST STRAIGHT SECTION DOWNSTREAM FROM INTERFERENCE. HORIZONTAL OR VERTICAL LINE CAN BE USED, PROVIDED THAT PIPE IS FULL AT THE MEASUREMENT PLANE.
2. PITOT TAPS MUST BE PLACED IN MAIN SUPPLY HEADER OR IN ALL FEED LINES TO TOWER.
3. PITOT CONNECTIONS: SEE FIG. 3.

REV 1.061213

Figure 7: Scaffolding Requirements for Plume Abatement or Drift Testing

PLAN VIEW

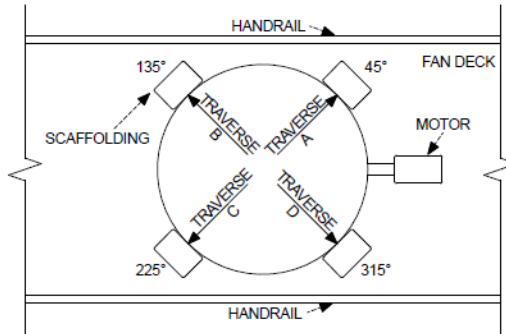

SIDE VIEW

NOTE: TYPICAL ARRANGEMENTS ARE SHOWN BY OPTION 1 OR OPTION 2.

OPTION 1: CABLE TRAVERSE

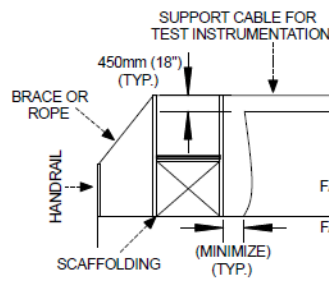

OPTION 2: BOOM TRAVERSE

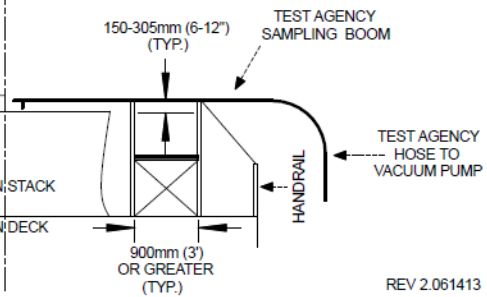

REV 2.061413

Part IX

Appendix C

Pre-Test Checklist Guidelines

	Yes	No	NCP	N/A
1.0 Arrangements for Test				
1.1 Request list of Licensed CTI Thermal Testing Agencies from: Cooling Technology Institute PO Box 73383 Houston, TX 77273 Phone: 281.583.4087 Fax: 281.537.1721 Internet Address: www.cti.org				
1.2 Test Scheduled with the CTI Test Representative and Manufacturer's Representative	_____	_____	_____	_____
1.3 All interested parties notified	_____	_____	_____	_____
1.4 Tower performance curves or characteristic curve received from the manufacturer	_____	_____	_____	_____
	Yes	No	NCP	N/A
2.0 Physical Preparation				
2.1 Pitot Traverse	_____	_____	_____	_____
a. Taps located and installed	_____	_____	_____	_____
c. Provision for safe and easy access to taps (scaffolding or manlift as necessary)	_____	_____	_____	_____
2.2 Cold water temperature tap installed or alternate location identified	_____	_____	_____	_____
2.4 110 VAC, 20 amp service available at the tower	_____	_____	_____	_____
2.5 Provide safe access to either isolate make-up or blow-down flows or measure flows and temperatures of all stream entering the cold water basin before the cold water measurement point. ___	_____	_____	_____	_____
3.0 Operating Conditions				
3.1 Water distributed equally over all operating test cells	_____	_____	_____	_____
3.3 The by-pass valve can be closed leak tight	_____	_____	_____	_____
3.4 Cooling tower water should be free of abnormal foam or other conditions	_____	_____	_____	_____
3.5 All fans on high speed operation	_____	_____	_____	_____
3.6 Range of +/- 20% of design	_____	_____	_____	_____
3.7 Expected Wet Bulb +/- 8.5°C (+/- 15°F) of design	_____	_____	_____	_____
	Yes	No	NCP	N/A

4.0 Condition of Components

- 4.1 Mechanical Equipment
 - 4.1.1 Fan blades set for proper power consumption _____
 - 4.1.2 No abnormal vibration _____

- 4.2 Drift Eliminators
 - 4.2.1 No eliminators are damaged or missing _____
 - 4.2.3 Eliminators are clean of algae, scale or foreign material
top side bottom side _____

- 4.3 Water Distribution
 - 4.3.1 Water distribution is functioning properly, uniform and free of broken
pipes _____
 - 4.3.2 No nozzles are broken or missing _____

- 4.4 Fill
 - 4.4.1 No significantly damaged or missing fill is present _____

5.0 Miscellaneous

- 5.1 Arrange for electrician to assist with measurement of
power to fan motors _____
- 5.2 Notify the CTI Test Representative in advance if fan
motor voltage is greater than 600 V _____
- 5.3 Arrange safety requirements and security clearance for test
personnel and equipment, and requirements for certificate
of insurance, etc. _____
- 5.4 Arrange for special site requirements such as vehicle passes,
safety equipment and safety orientation, or special training _____
- 5.5 Arrange for additional personnel to assist the CTI Test
Representative as necessary _____
- 5.6 Notify the CTI Test Representative of any unusual situations
or test requirements _____

Remarks: _____

NCP – No Check possible

N/A – Not applicable

* Required only for natural draft and forced mechanical draft tower

** List either elevation or barometric pressure

*** Required only for mechanical draft cooling towers



COOLING TECHNOLOGY INSTITUTE

P.O. Box 73383 Houston, Texas 77273 281.583.4087 FAX 281.537.1721

Printed in U.S.A.