

INSTALLATION AND MAINTENANCE INSTRUCTIONS

DG II Anti Rotation Device®



DG-II Installation Video-2023
<https://youtu.be/CVn1W5XiakA?t=1>

The DG-II, ARD utilizes a Formsprag clutch having its own ball bearing with integral seals, special long term grease, a clutch housing, stub shaft adapter (stub shaft), cable assembly and torque arm. This design prevents (unwanted) reverse rotation of shafts in applications for ACHEs (air cooled heat exchangers) with vertical shafts.

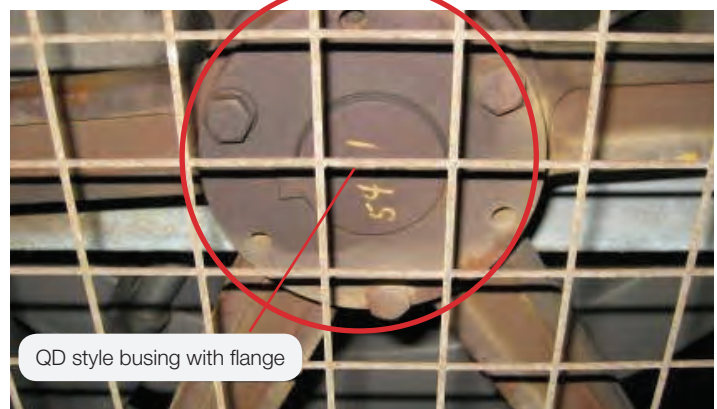
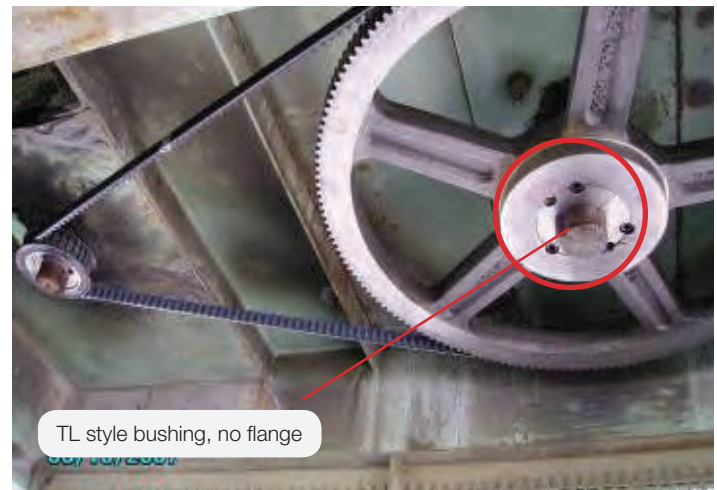
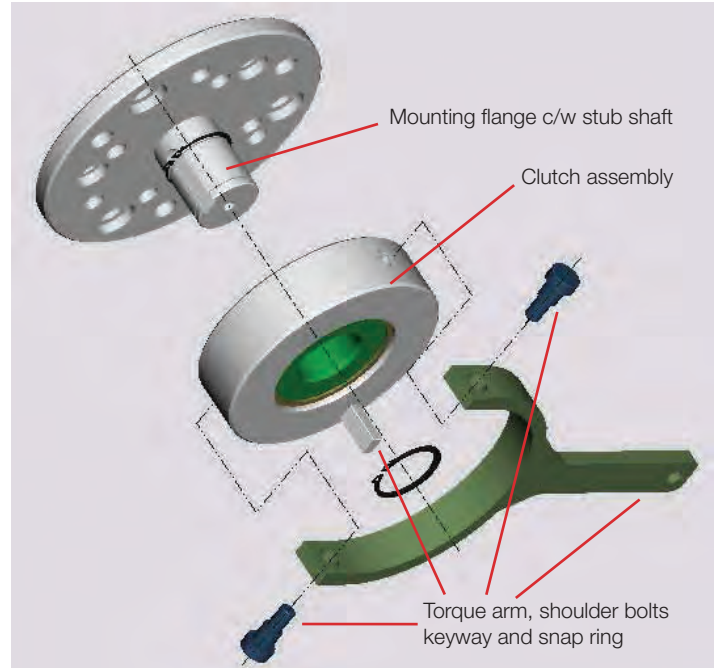

IMPORTANT - READ FIRST

Pre-Installation Instructions

Review this diagram to identify the various components of the model DG-II, ARD. Also read the first 3 pages of these instructions to ensure you fully understand what system you are mounting to, as well as, understanding all your options and challenges.

The new DG-II is advanced over previous ARD models and is very versatile. This one single unit with the Patented universal spacer provided can be mounted in several different ways to cover every possible combination of Air Cooled Heat Exchangers (ACHEs).

WARNING: Failure to follow these instructions may result in product damage, equipment damage, and serious injury or death.

Fan Options

1 Option one, is the most common. This option mounts the DG-II to the bottom of the existing large driven pulley bushing (on the main vertical fan shaft) using one of the many hole combinations on the mounting flange. **You MUST determine the correct bushing part number you have.** There are two common types of bushings used for ACHEs. One type is called taper lock (TL) and these bushings don't have flanges. The mounting screws are half in the pulley and half in the bushing. The TL bushings that this DG-II will mount to (using universal spacer provided) are 3020, 3525, 3535 and 4030. The second type of bushing is the QD style. These bushings have flanges and are very simple to mount the DG-II. The enclosed universal spacer is not required when you have QD bushings. The DG-II has QD mounting holes for E, F and J bushings. Even if the QD bushings you are using have the flanges on the top we can still mount the DG-II. The pulley face for the QD design has three drilled and threaded holes that are used as bushing removal holes. These are the holes we would mount the DG-II to. For this new DG-II the "J" holes are located with 1/4" pilot holes only as this "J" is not as popular as it was 15 years ago. If you need to mount to a "J" bushing simply drill the holes to 21/32" through holes. Counter sinking these holes is not required, but they can be counter sunk 1" x 1/2" deep to keep the mounting profile as low as possible.

2 Option two is to use the C-ring device to mount the DG-II to any shaft end, as long as the fan shaft extension is more than 1.25". The C-ring provides an easy mount if your fan shaft extends past any bushing. **See separate instruction section "B" for C-ring mounting on page 7.**

3 Option three would be to provide all the details of your system and we will custom build a flange to suit your requirements. A picture of the area and some dimensional details are needed.

4 Option four would be to build your own bracket off the bottom of the fan shaft, pulley or bushing. Once you have a flat, level plate with 3 drilled and tapped holes evenly spaced on a 5" bolt circle, the rest is simple.

Tip

The trick for easy installation is to measure the extension of your fan shaft (below the bushing). The DG-II ARD is designed with a very low profile to allow it to fit under the fan shaft without having to modify the bottom fan guard (saving cost and installation time). If your existing fan shaft extends past (below) the bushing by more than 15/16" you will need additional universal spacers, only if you have TL bushings, or the unit will not fit. If your bushings are QD style you can simply use longer mounting bolts. Or use the C-ring mount shown in section B. Many fan shafts are flush with the bushing which is perfect for mounting the DG-II.

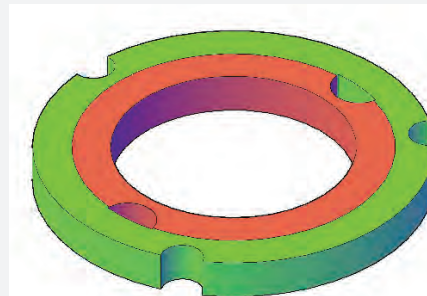

Patented Universal Spacer supplied in each DG-II kit. This "two-in-one" spacer is needed (only) when mounting to pulleys with TL style bushings.

Patents:
2,665,772/2,127,726/5,562,418

FAQ:

Why is there a ½” thick spacer with my DG-II?

The spacer is only required for TL bushing mounting. Extra spacers can be purchased if your fan shaft extends past the bushing by more than 15/16” before the DG-II is mounted. It is critical for TL bushing mounts that the mounting face of our DG-II is contacting the bushing face and not the end of the shaft or pulley – **failure to follow these instructions can cause the unit to fail resulting in damage to equipment.** This is why we have provided this unique “two in one” spacer. The smaller inside spacer is used when you have a 3020 TL bushing. To get the smaller spacer simply tap the spacer with a hammer and the two spacers come apart. Place the spacer on top of the mounting flange of the unit as you bolt the DG-II to the bushing face. The larger outer spacer ring covers the rest of the TL bushings (3525, 3535 and 4030/4040). Keep the two parts together for all mounting applications except the 3020. Other spacer sizes for other TL bushings that are not covered here can be provided.

Can I use my existing bushing bolts?

The QD bushing bolts are not a factor as we don't take them off for mounting the DG-II. The TL bushing bolts are a factor as we take them off and use longer bolts in the same mounting holes to mount the DG-II. The ½” thick universal spacer used for TL mounting will require longer bolts. See chart on page 5 for the bolt length and information you will need once you determine which bushing you have. You will need longer bolts than we have designated in the chart (page 5), only if the fan shaft extends more than 15/16” past your TL bushing. We have designed the spacer and counter bores to fit standard bolts from your bolt bins. So simply add a ½” longer bolt for each extra spacer used only if more than one spacer is required.

How large of a fan shaft can the DG-II accommodate?

This unit is built to fit over fan shafts as large as 3” diameter. If the keyway sticks down past the bushing or pulley it will have to be taken off and or cut off or pushed up the fan shaft. If your fan shaft is over 3” contact us directly with the details and we will provide a custom mounting flange for your ACHes.

Fan Shaft Rotation

The new DG-II is able to handle anti-rotation for both fan directions. The majority of vertical shaft ACHes have the fan running in the counter clock wise (CCW) direction when you are viewing the fan from under the unit (where the belt drive is located). This is known as an RH (right hand) fan.

The DG-II is set up for this RH direction. So make sure the part number (label) on the clutch is facing down after installation. Also perform one more final check before you try to start the electric motor. You can do this by turning the fan shaft (by hand) in the correct direction once the torque arm is attached. If the DG-II is not allowing the fan shaft to turn then you may need to turn the main assembly unit over or double check your fan design.

If your fan shaft is turning clock wise (CW) or if the belt drive assembly is on top, install the clutch assembly upside down, as this DG-II will work in both directions.

We have also experienced left hand (LH) fans (meant for horizontal engine drives) installed on vertical shaft ACHes. If you view the fan from the bottom and the proper fan direction when running is CW then reverse the clutch assembly and it will work fine.

WARNING: Failure to follow these instructions may result in product damage, equipment damage, and serious injury or death.

Section “A”: Installation Onto Fan Pulley Bushing (QD or TL)

Go to Section “B” on Page 7 if Using Optional C-Ring Assembly

The first step is to mount the stub shaft assembly to the vertical fan shaft, read this section below. Use Step 1-A for QD and Step 1-B for TL bushing mounts.

The stub shaft has a series of bolt patterns so it can be adapted to the most common QD and Taper-Lock (TL) bushings. Be sure the bushing is an E, F, J, 3020, 3525, 3535 or 4030/4040. If you have a different bushing, contact Vibe.FX directly for assistance – please see contact information at the back of this document.

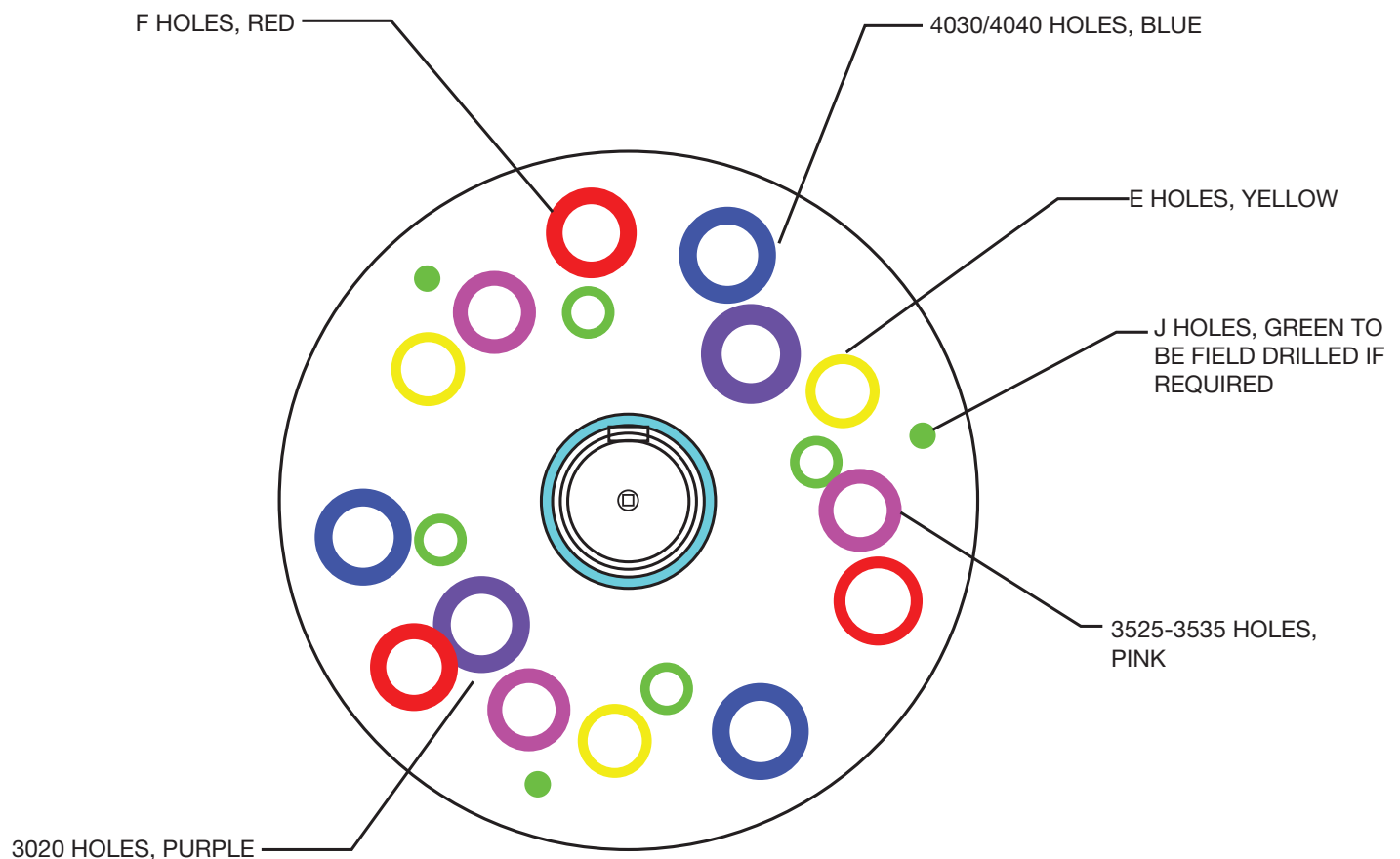

WARNING: Failure to follow these instructions may result in product damage, equipment damage, and serious injury or death.

Step 1 A (For E, F or J bushings)

If you have E, F or J bushings, use the empty threaded holes on the bushing to mount the unit's stub shaft. Use standard bolts (not provided, see bolt chart below) to bolt through the matching holes of the DG-II. There is no need to remove the existing bolts that are holding the large sprocket or sheave. If your QD bushing was mounted with the flange on top, mount to the threaded holes on the pulley face at the bottom. There is no need to use the "Universal Spacer" for these QD bushing applications.

The length of bolt for QD mount is determined at installation. The bolt has to span the distance through the flange of the DG-II unit and engage all the threads of the QD bushing without protruding or touching the pulley face on the other side. The bolt torque to hold this unit in place is snug with Loctite.

Proceed to steps 2, 3, 4 and 5 on page 6.

Step 1 B (For 3020, 3525, 3535 or 4030/4040 TL bushings)

If you have 3020, 3525, 3535 or 4030 TL bushing, you will need to use the "Universal Spacer" provided and new mounting bolts (bolts not provided, see bolt chart below).

This spacer connects the mounting force directly onto the bushing face of the TL bushing which is critical for proper installation and to avoid the possibility of the unit failing.

You need to undo the existing cap screws on the bushing that secures the large sprocket or sheave, and use new socket head cap screws (not provided) to mount into these same holes.

CAUTION: When you undo these cap screws be sure you secure the sheave or sprocket from falling and causing personal injury.

Refer to the bolt chart below for size and torque specifications. The "Universal Spacer" is unique as it is two spacers in one. Keep the spacer as supplied for all TL bushings except the smaller size 3020. For the 3020 you need to tap the spacer with a hammer and knock out the inside ring. Use this inside ring for the 3020 TL bushing and discard the outer ring, as it is not required for the 3020 mount.

The spacers are 1/2" thick and the DG-II has a 1/2" counter bore on the mounting face. If your shaft extends more than 15/16" you will need extra spacers and longer bolts than what we display in this chart below. We have designed the spacer thickness and counter-sunk depths special to use standard bolts and one 1/2" spacer. If you need more spacers make sure you add 1/2" longer bolts for each extra spacer used. Contact us for extra "Universal Spacers," if required.

Bushing	Qty.	Bolt Type	Dimension	Torque (inch-lbs)
E	3	SHCS	1/2 UNC	Snug with Loctite, no washer
F	3	SHCS	9/16 UNC	Snug with Loctite, no washer
3525	3	SHCS	1/2 UNC x3" *	1000
3535	3	SHCS	1/2 UNC x3" *	1000
4030/4040	3	SHCS	5/8 UNCx 3.25" *	1700
J	3	SHCS	5/8 UNC	Snug with Loctite, no washer
3020	2	SHCS	5/8 UNCx 2" *	800

* Bolt length in this chart is when using one 1/2" thick spacer provided. If your shaft extends more than 15/16" you need to buy additional spacers. For each extra 1/2" thick spacer needed, you need to also add an extra 1/2" length to the above bolt chart.

Proceed to steps 2, 3, 4 and 5 on page 6.

WARNING

The bolt force must be directly on the face of the taper lock bushing (3020, 3525, 3535 or 4030), the clutch stub shaft surface must not press against the pulley face or fan shaft end. Failure to follow these instructions may result in property damage, serious personal injury or death.

The DG-II is built for mounting directly onto the fan pulley bushing. If the shaft protrudes beyond the bushing by more than 15/16" then it must be shortened or add extra spacers of adequate thickness must be used. Alternatively, if there is at least 1 1/4" of shaft length available, the optional C-Ring can be used. See section B of the instructions below for the C-ring mount option.

Step 2

With a dial indicator, adjust the stub shaft to be concentric with the fan shaft within .003" TIR.

Step 3

Attach the torque arm using the shoulder bolts supplied. Snug with Loctite 262.

Step 4

Coat the stub shaft with anti-seize compound. Install the key into the keyway of the stub shaft, and slide the clutch assembly on to the stub shaft. Assemble bottom snap ring to the stub shaft.

Step 5

Attach torque arm stops to equipment frame or supporting structure. The stops are required to prevent rotation of torque arm when hold back torque is applied. Allow clearance between stops and torque arm as shown in the figure. Make sure the torque arm stops can handle the rated torque of the backstop.

Torque arm stops. Ensure that appropriate equipment frames or structures are available for fastening stops for the backstop's torque arm as shown in the figure below. Make sure the stops do not contact the corner radii of the torque arm. If a braided steel cable is used instead of stops, install a shackle into the hole in the torque arm, as shown in the figure, and tie the cable to the shackle.

Make sure the torque arm is perpendicular to the torque arm axis within 10 degrees.**

Do not use a rigid system to hold the torque arm.**

**Failure to do so may result in unit failure due to uneven bearing loads.

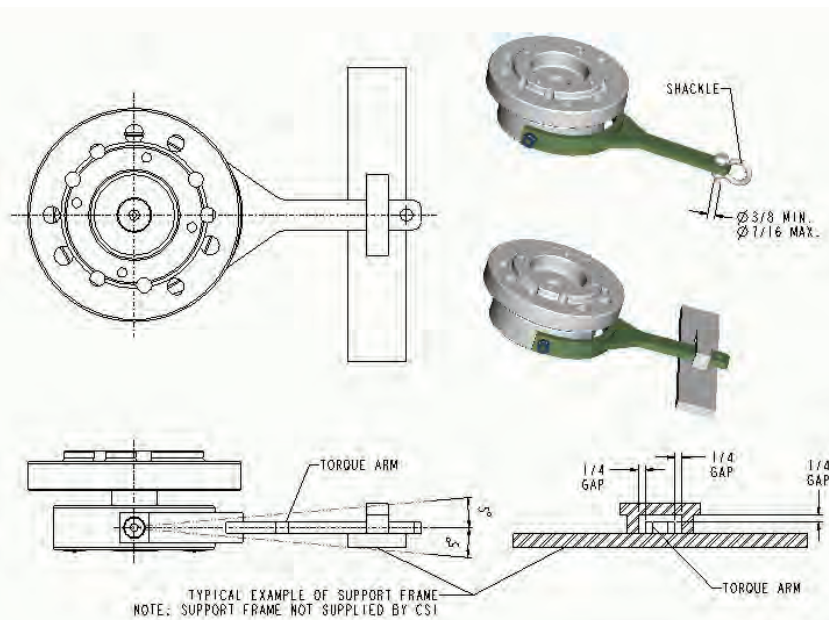

Cable system is supplied in each kit



Section “B”: Installation with Optional Spigotted C-Ring Assembly

The Locking Ring Kit allows mounting of the DG-II Anti-Rotation Device to shafts where it is not possible to mount to the pulley bushing due to fan shafts sticking out far enough (> 1”) to mount the C-ring directly onto the end of the fan shaft. Our standard C-ring is 1.5” wide but we also offer a .875” wide C-ring, if required

Required Items

C-Ring Kit comes with;

- One piece locking ring bored to 1 ¼”
- 1 each 3/8-16 Socket Head Cap Screw
- 4 each 5/16-18 Socket Head Cap Screw

Installation Steps

See pages 10 and 11 for visual tips using C-ring

1. Bore the Locking Ring to the shaft diameter within ± 0.001 inch. Keyway optional, but preferred on the 7/8” wide C-ring.
2. Cut the 0.050 inch wide slot as shown in Figure 2. A standard band saw can be used. Saw must follow path shown in figure 2 and stop at drilled hole opposite of 3/8” bolt.
3. Attach the finished C-Ring to the Stub Shaft with the (4) 5/16-18 SHCS finger tight.
4. Match the female spigot on the C-ring to the 3.25” male spigot on the stub shaft.
5. Install the C-Ring/Flange Plate with Stub Shaft assembly onto the shaft.
6. Apply Loctite 262 Thread locker to the 3/8-16 SHCS and torque to 250-300 lb-inch.
7. Apply Loctite 262 Thread locker to the 5/16-18 SHCS and torque one at a time to 100 lb-inch. Torque in the same sequence to 200-250 lb-inch.
8. Complete installation per the DG-11 Anti-Rotation Device Installation and Maintenance

Tip

Installation Tip: Pre-mount the clutch onto and torque arm onto the stub shaft so everything goes on as one unit with the C-ring already bolted onto the stub shaft.

NOTE: Do not torque each cap screw to the final torque value in one operation as it may cause misalignment between the Stub Shaft and the locking ring.

C-Ring Kit



Figure 1: Flange plate c/w stub shaft

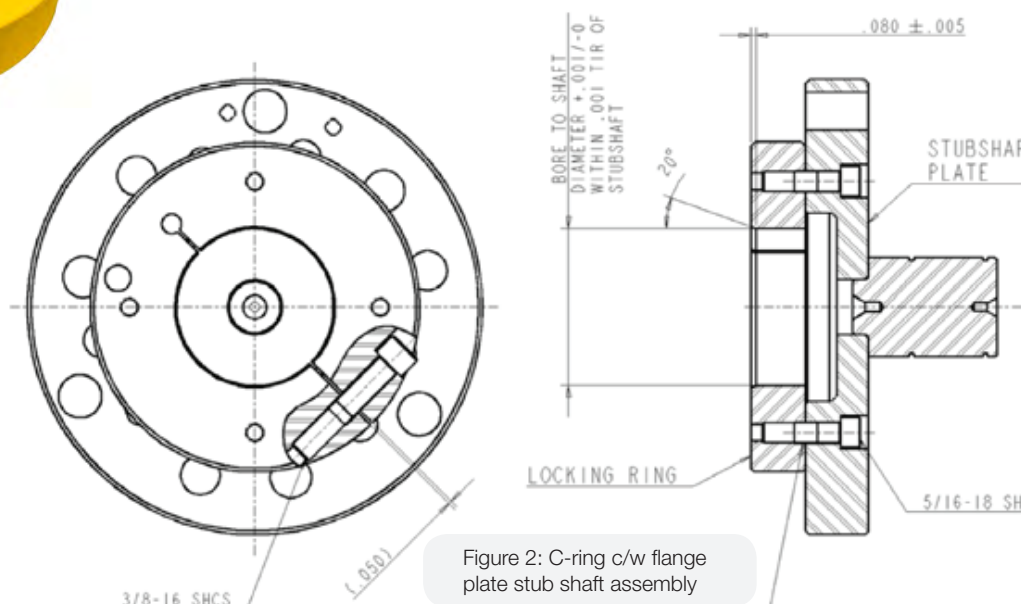

Figure 2: C-ring c/w flange plate stub shaft assembly

Vibration Troubleshooting

1. If unacceptable levels of vibration occur upon installation, disassemble and reinstall, being sure to tighten fasteners as described, verify that the stub shaft adapter sits flush with the bushing or with the optional C-Ring assembly, and that the C-Ring assembly is not bottomed out against the mating shaft. Also verify that the torque arm is not bound in any way, but is free to float against its stops.

2. Verify that the stub shaft diameter run out does not exceed 0.003".

See next page for visual with dial indicator being used

Lubrication and Maintenance

The DG-II comes lubricated for life and there is no way to add new lubrication.

To remove clutch assembly:

- A. Remove the two shoulder screws to free the torque arm.
- B. Slide the clutch assembly off the stub shaft adapter. Visually inspect the key.
- C. Clean the stub shaft thoroughly, coat with anti-seize, reinstall the clutch assembly (check for correct direction of rotation), slide in the key and install the snap ring on the stub shaft adapter.

QUESTIONS?

If you have any questions, please feel free to contact Nick Agius at any time by email:

nick.agius@shaw.ca
by phone: 780-719-7413

DANGER

Rotating Equipment

Rotating equipment is potentially dangerous and should be properly guarded. The user should check for all applicable safety codes (in local area) and provide a suitable guard. Failure to use a proper guard may result in property damage, serious personal injury or death. For application assistance, contact TheFanGuy.ca



Warranty

TheFanGuy.ca warrants that it will repair or replace (whichever in its sole discretion it deems advisable) any product it manufactured and sold which proves to be defective in material or workmanship within a period of one (1) year from the date of original purchase for consumer, commercial or industrial use. This warranty extends only to the original purchaser and is not transferable or assignable without TheFanGuy.ca prior consent. This warranty covers normal use and does not cover damage or defect which results from alterations, accident, neglect, disassembly, or improper installation, operation, or maintenance. TheFanGuy.ca obligation under this warranty is limited to the repair or replacement of the defective product. In no event shall TheFanGuy.ca be liable for consequential, indirect or incidental damages of any kind incurred by reason of manufacture, sale or use of any defective product. TheFanGuy.ca neither assumes nor authorizes any other person to give any other warranty or to assume any other obligation or liability on its behalf.

RE: Dial indicator for DG-II ARD

MS Mariusz Stachowiak <m.stachowiak@vibefx.ca>
To: nickagius2014@gmail.com
Cc: Russell Dejesus; Bryce Harper



Hey Nick,

I just used the angle iron we have in the truck and clamped it across using vise grip C clamps. This method does not work all the time as you might imagine, its up to the installer to come up with ways to mount the mag base.

Cheers,
Mario



If this was my installation I would cut the extended key as it is not a good practice to have any key sticking down past pulley. The C-ring design will hold 100%-force without a key-way but if you elect to cut a key-way into C-ring make it opposite the band saw cut (see instructions to bore C-ring for your job page 3 of this file).



Ideal C-ring mount opportunity as shaft sticks down past bushing face by more than 1"

This page will help you decide how to mount the DG-II kit properly. This picture shows a fan pulley (bottom) with a taper lock (TL) bushing but the shaft extends past the bushing face by 3/4".

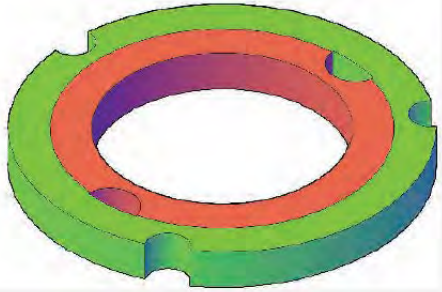

Patented Universal Spacer supplied in each DG-II kit. This "two-in-one" spacer is needed (only) when mounting to pulleys with TL style bushings.

If the actual key extends down past bushing face you either cut it off or check to see if it clears the counter bore of our DG-II and Universal spacer, which is 3 1/4" max.

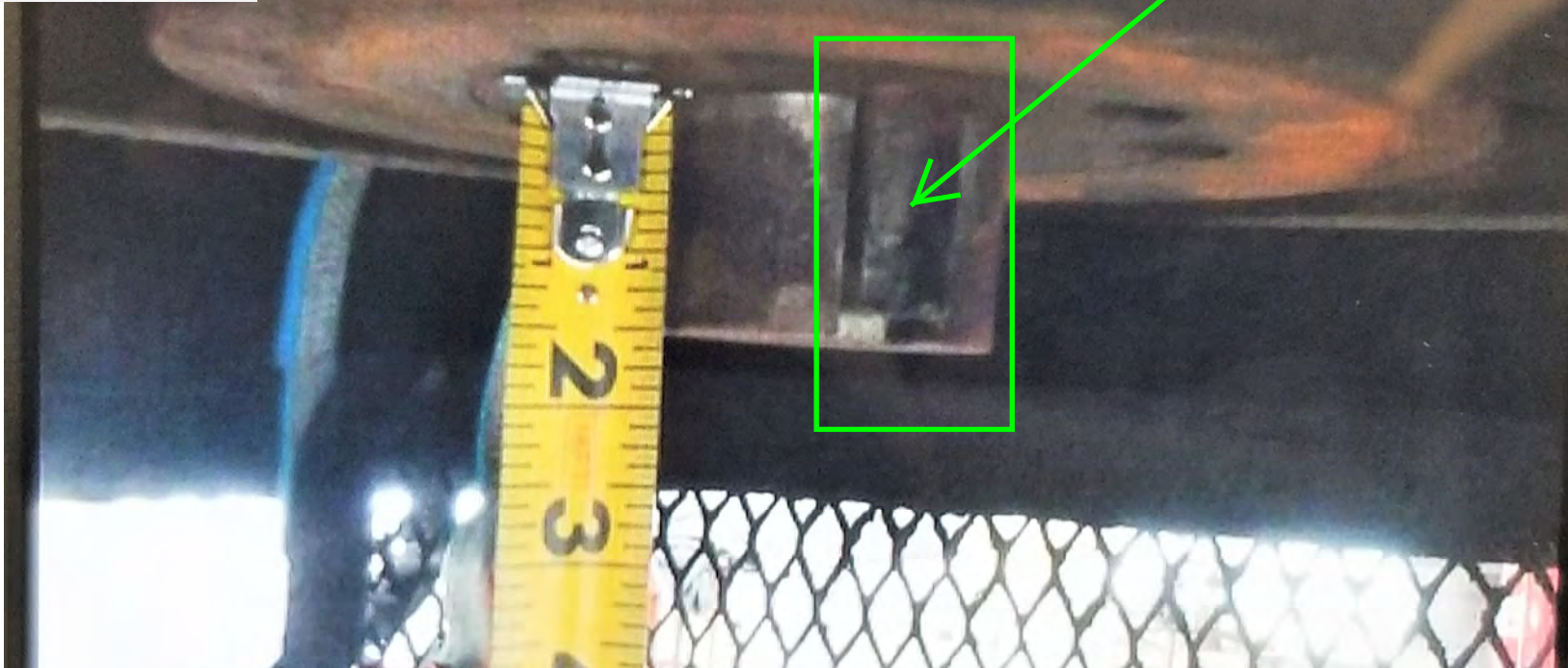

With this style Taper-lock bushing you must use the **universal spacer** that comes in the kit as per instructions **if you plan to mount directly to the pulley bushing**. The DG-II kit has 1/2" counter bore and the Universal spacer is 1/2" so this 3/4" shaft extension is ideal for direct mounting **(no C-ring required)**.

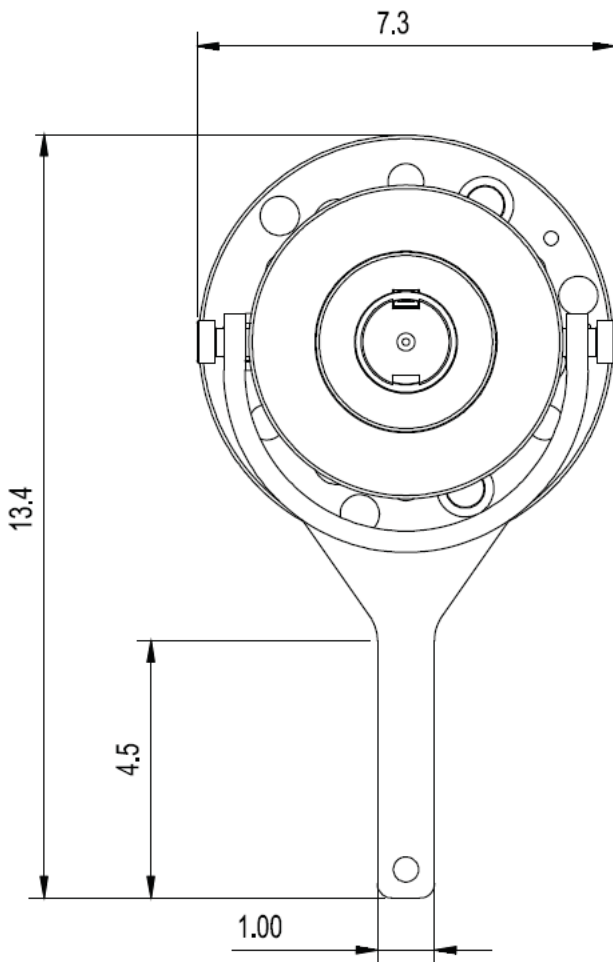
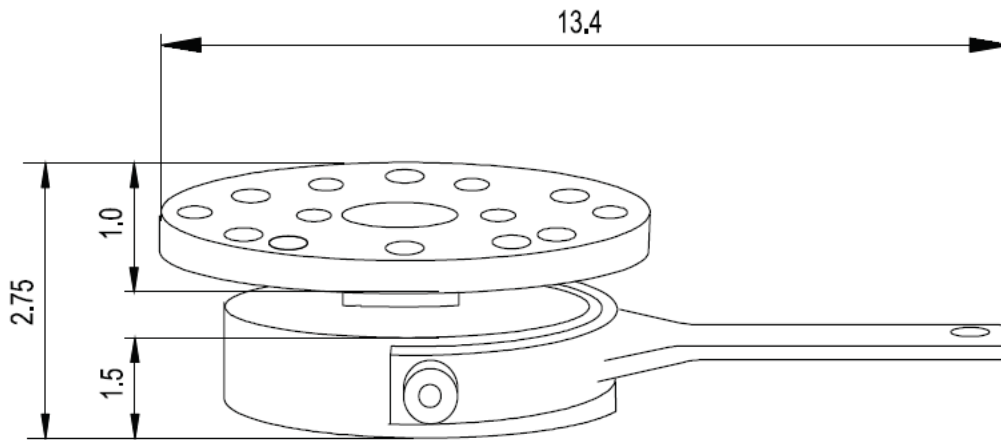

Weight: The total weight of the DG-II kit is 24lbs